

RESIDENTIAL PLASTIC SEATS



Seats shall be No. 170 as manufactured by Church Seats. Seats shall be standard weight and injection molded of solid plastic. Seats shall be closed front with cover for elongated bowl and feature molded-in bumpers. Color-matched Top-Loc® hinges with non-corrosive top-tightening bolts and wing nuts. Color to be _____. (specify white or fixture manufacturer's color.)

MODEL 170

- ELONGATED SEAT
CLOSED FRONT WITH COVER
- SOLID PLASTIC
- TOP-LOC® HINGE

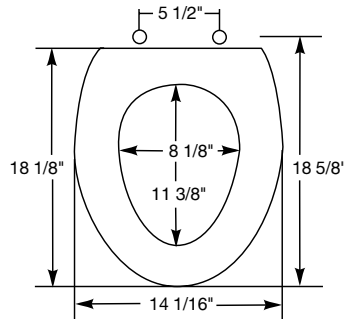

Ring thickness is 3/8"
Ring thickness including the bumper is 5/8"
Height of the seat with cover is 1-1/2"

