

COMMERCIAL PLASTIC SEATS



Seats shall be No. 2150 as manufactured by Church Seats. Seats shall contain DuraGuard®, an antimicrobial agent. Seats shall be commercial weight and injection molded of solid plastic. Seats shall be open front with cover for elongated bowl and feature large molded-in bumpers. Hinges and pintles feature 300 Stainless steel. Color to be white.

MODEL 2150

- ELONGATED SEAT
OPEN FRONT WITH COVER
- SOLID PLASTIC
- DURAGUARD®
ANTIMICROBIAL AGENT

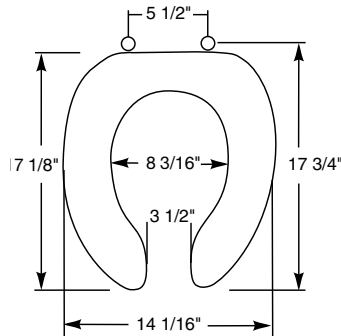

Ring thickness is 3/4"
Ring thickness including the bumper is 1-1/16"
Height of the seat with cover is 2-1/4"

