

Model 404 and 405 Automatic Drain Pump



MODEL 404 Residential
115 volt



MODEL 405 Commercial 115 volt
MODEL 405HV Commercial 230 volt

Contents

- 1.) General Information and Safety Guidelines
- 2.) Installation
- 3.) Maintenance and Troubleshooting

IMPORTANT:

Prior to installation, record Model, Serial Number, and Code Number from pump nameplate for future reference.

MODEL _____

SERIAL _____

CODE _____

1. General Information and Safety Guidelines

Before installation, read the following instructions carefully. Each Liberty pump is individually factory tested to insure proper performance. Closely following these instructions will eliminate potential operating problems, assuring years of trouble-free service.

⚠ WARNING

- **Risk of electric shock.** Always disconnect the pump from the power source before handling or making adjustments.
- The electrical connections and wiring for a pump installation should only be made by qualified personnel.
- This pump is supplied with a grounding conductor and grounding-type attachment plug. To reduce the risk of electric shock, be certain that it is connected only to a properly grounded, grounding-type receptacle.
- Do not bypass grounding wires or remove ground prong from attachment plugs.
- Do not use an extension cord.
- This pump requires a separate, properly fused and grounded branch circuit. Make sure the power source is properly sized for the voltage and amperage requirements of the pump, as noted on the nameplate.
- The electrical outlet shall be within the length limitations of the pump power cord, and at least 4 feet above floor level to minimize possible hazards from flood conditions.
- The installation must be in accordance with the National Electric Code and Plumbing Codes as well as all applicable local codes and ordinances.

⚠ CAUTION

- **Model 404** Do not use this pump in water over 140° F.
- **Model 405** Do not use these pumps in water over 180° F

2. Installation

Fig. 1 – Typical Residential Installation
This is a recommended installation only.

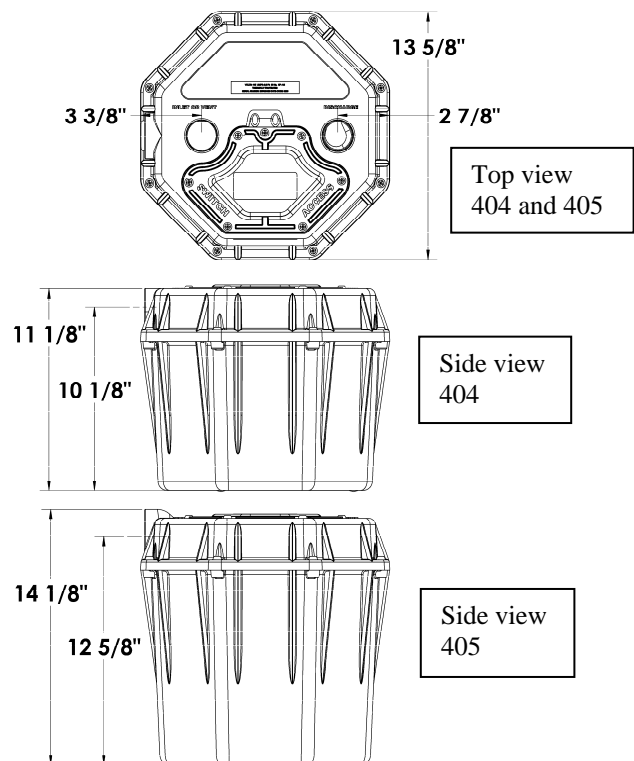
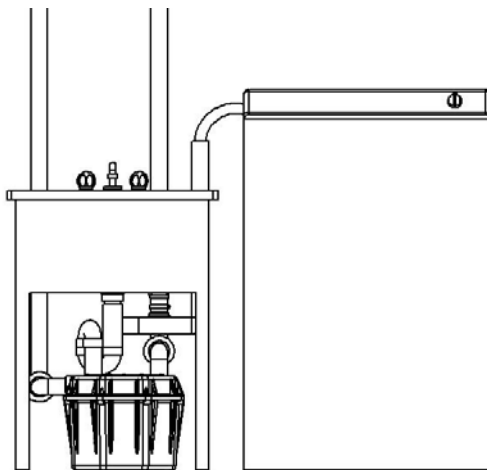

Dimensions are rounded to the nearest 1/8"

INLET: The pump has two ports: one on the top the other on the side, either can be used as a vent or inlet. Using the appropriate piping (1-1/2" on the model 404 and 2" on models 405, 405HV) connect the fixture to the pump. Note: a trap shall be used between the fixture and pump, a flange type is recommended. **HAND-TIGHTEN TO PUMP. DO NOT OVERTIGHTEN OR CROSS-THREAD.**

- A. **DISCHARGE:** HAND-TIGHTEN ONLY. Install a union just above the pump to facilitate removal if necessary for cleaning or service. Install a check valve just above the union (as close to the pump as possible) to prevent the backflow of water after each pump cycle.
- B. **VENT:** Provision is made for a vent stack to allow extra volume for high suds conditions, and to allow proper drainage of the fixture. **HAND TIGHTEN ONLY. DO NOT CAP-OFF VENT,** venting methods (**ONE-WAY QUICK-VENTS**) must comply with local and national codes One way quick vents should not be threaded into this product directly. Follow manufactures installation instructions. The vent pipe should have a union to facilitate removal if required and be connected to the building or house vent.
- C. **POWER CORD:** The pump power cord is equipped with a grounding conductor and grounding-type 3-prong plug. It should be connected to a separately fused, grounded, 3-wire grounding-type receptacle of 15-amp capacity with the proper voltage for your model. Make sure all electrical wiring and connections are in accordance with the National Electric Code and all applicable local codes.
- MODEL 404 - 115 volts
MODEL 405 - 115 volts
MODEL 405HV - 230 volts

⚠ WARNING

- **Risk of electric shock.** Always disconnect the pump from the power source before handling or making adjustments.
- **DO NOT** remove the plug or ground prong.
- **DO NOT** use an extension cord.

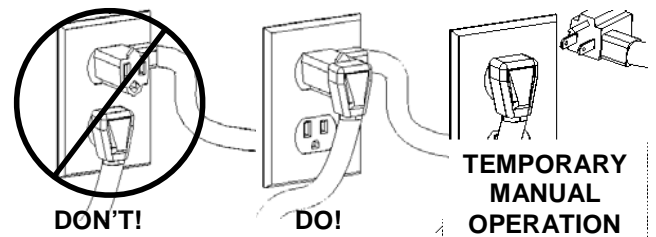

The 404 and 405-series pumps come factory-equipped with a float switch mounted within the tank. These models come with two cords - one to the float switch and the other to the pump motor. The switch cord has a series (piggyback) plug enabling the pump cord to be plugged into the back of it (see Fig. 4). The purpose of this design is to allow temporary manual operation of the pump.

For automatic operation using Liberty's supplied switch, the two cords should be interconnected and plugged into a separately fused, grounded outlet of proper amp capacity for your selected pump model. (See the pump's nameplate for electrical specifications of your model.) Both cords are equipped with 3-prong plugs and must be plugged into a properly grounded 3-wire receptacle. **DO NOT REMOVE THE GROUND PRONGS.**

For manual operation, or in the event of switch failure, the pump cord can be separated and plugged into the electrical outlet, directly bypassing the switch. 208-230V single phase pumps should only be operated without the float switch by using the circuit breaker or panel disconnect. Do not let the pump run dry for extended periods.

Application: The 404 and 405-series drain pumps are designed for use in gray wastewater applications. They will handle small debris and solids such as laundry lint (up to 3/8") associated with normal gray water drainage from a sink. Larger solids should be kept out of the pump system. The 405-series is designed for commercial applications where higher temperature drain water (up to 180 degrees F.) may be used.

3. Maintenance and Troubleshooting

Each unit is individually factory tested to ensure proper adjustment and operation. If the unit fails to operate properly, carefully re-read the instructions to see that they have been followed correctly. Routine maintenance is not required on the pump itself, but associated connections may require occasional attention. Lint and foreign objects should be removed from the trap periodically. The check valve on the discharge should also be checked for freedom of operation at the same time.

The pump is automatically turned on and off by use of a float switch mounted within the tank. This switch can be easily removed and checked for operation by removing the access cover located on top of the unit. Once the access cover has been removed a rubber plug must be lifted to free up the switch cord. The switch is mounted to a rod which can be removed by lifting or pulling upward. **IMPORTANT: Do not adjust the tether length. If replacing the switch, make sure to maintain the correct tether length for your model per the following diagram. (Tether length is the distance of cord measured between the clamp and top of float switch.)**

***NOTE:** Liberty Pumps, Inc. assumes no responsibility for damage or injury due to disassembly beyond float removal in the field. Disassembly, other than at Liberty Pumps or its authorized service centers, automatically voids warranty.

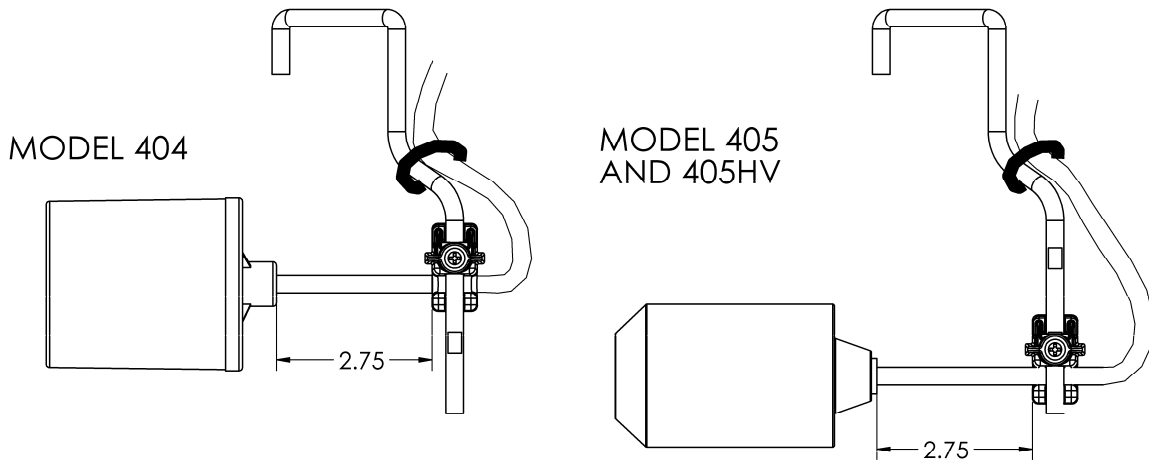

Problem	Cause	Correction
Pump will not turn on or shut off.	<ul style="list-style-type: none"> Blown fuse or other interruption of power; improper voltage. 	<ul style="list-style-type: none"> Check that the unit is securely plugged in. Have an electrician check all wiring for proper connections and adequate capacity.
	<ul style="list-style-type: none"> Plugged vent, or quick-vent in use. 	<ul style="list-style-type: none"> Be sure that an unrestricted vent at least 1-1/4" in diameter is in use.
	<ul style="list-style-type: none"> Defective switch or build-up on tank wall restricting free movement of float switch. 	<ul style="list-style-type: none"> *Remove access cover and check that float is free to move. If build-up restricts float, clean and reinstall. If defective, replace switch.
Pump runs or hums but does not pump.	<ul style="list-style-type: none"> Discharge is blocked or restricted. 	<ul style="list-style-type: none"> Check the discharge line for blockage, including ice if the line passes through or into cold areas.
	<ul style="list-style-type: none"> Check valve is stuck closed or installed wrong. 	<ul style="list-style-type: none"> Remove and examine for freedom of operation and proper installation.
	<ul style="list-style-type: none"> Total lift height has been reached (see Fig. 2) 	<ul style="list-style-type: none"> Try routing pipe to a lower level. If not possible, another pumping station may be required at a level of roughly half the total lift.
	<ul style="list-style-type: none"> Pump impeller is jammed. 	<ul style="list-style-type: none"> *Disassemble the receiver and bottom base of pump. Remove foreign material. Reassemble.
	<ul style="list-style-type: none"> Trap or inlet piping is clogged. 	<ul style="list-style-type: none"> Check the trap and inlet piping for restrictions.
Pump short-cycles.	<ul style="list-style-type: none"> Plugged vent, or quick-vent in use. 	<ul style="list-style-type: none"> Be sure that an unrestricted vent at least 1-1/4" in diameter is in use.
	<ul style="list-style-type: none"> Defective switch. 	<ul style="list-style-type: none"> *Remove access cover and check that float is free to move. If build-up restricts float, clean and reinstall. If defective, replace switch.
	<ul style="list-style-type: none"> Check valve was not installed, is stuck open, or is leaking. 	<ul style="list-style-type: none"> Remove and examine for freedom of operation and proper installation.

Pump runs periodically when fixtures are not in use.	<ul style="list-style-type: none"> • Check valve was not installed, is stuck open, or is leaking. 	<ul style="list-style-type: none"> • Remove and examine for freedom of operation and proper installation.
	<ul style="list-style-type: none"> • Faucets are dripping. 	<ul style="list-style-type: none"> • Repair faucets to eliminate dripping.
Water or soap suds come out of vent pipe.	<ul style="list-style-type: none"> • Vent pipe is too short or too small in diameter. 	<ul style="list-style-type: none"> • Be sure that an unrestricted vent at least 1-$\frac{1}{4}$" in diameter is in use.
	<ul style="list-style-type: none"> • Defective switch. 	<ul style="list-style-type: none"> • *Remove tank cover and check that float is free to move. If build-up restricts float, clean and reinstall. If defective, replace switch.
	<ul style="list-style-type: none"> • Rate of in-flow exceeds pump output. 	<ul style="list-style-type: none"> • Use valve on the inlet to reduce rate of inflow.
Pump operates noisily.	<ul style="list-style-type: none"> • Foreign objects in impeller cavity. 	<ul style="list-style-type: none"> • *Disassemble the receiver and bottom base of pump. Remove foreign material. Reassemble.
	<ul style="list-style-type: none"> • Piping to house structure is too rigid. 	<ul style="list-style-type: none"> • Replace a portion of the discharge pipe with rubber hose to absorb noise.

Figure 2

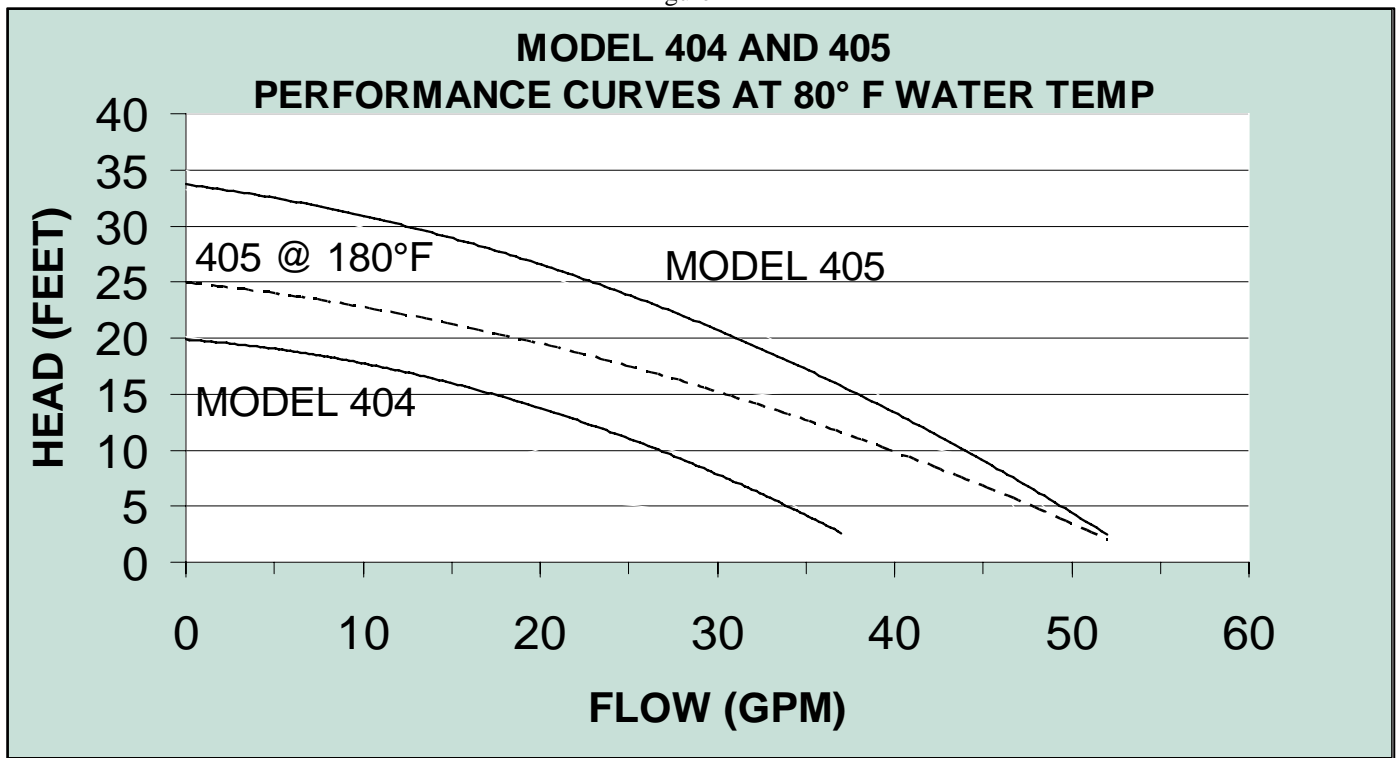

Year Limited Warranty Liberty Pumps, Inc. warrants that pumps of its manufacture are free from all factory defects in material and workmanship for a period of 2 years from the date of purchase. The date of purchase shall be determined by a dated sales receipt noting the model and serial number of the pump. The dated sales receipt must accompany the returned pump if the date of return is more than 2 years from the "CODE" (date of manufacture) number noted on the pump nameplate. The manufacturer's obligation under this Warranty shall be limited to the repair or replacement of any parts found by the manufacturer to be defective, provided the part or assembly is returned freight prepaid to the manufacturer or its authorized service center, and provided that none of the following warranty-voiding characteristics are evident: The manufacturer shall not be liable under this Warranty if the product has not been properly installed; if it has been disassembled, modified, abused or tampered with; if the electrical cord has been damaged or improperly spliced; if the pump discharge has been reduced in size; if the pump has been used in hot water above the ratings listed above; if the pump has been used in water containing sand, lime, cement, gravel or other abrasives; if the product has been used to pump chemicals or hydrocarbons; if a non-submersible motor has been subjected to excessive moisture; or if the label bearing the serial and code number has been removed. Liberty Pumps, Inc. shall not be liable for any loss, damage or expenses resulting from installation or use of its products, or for consequential damages, including costs of removal, reinstallation or transportation. **There is no other express warranty. All implied warranties, including those of merchantability and fitness for a particular purpose, are limited to two years from the date of purchase.** This Warranty contains the exclusive remedy of the purchaser, and, where permitted, liability for consequential or incidental damages under any and all warranties are excluded.