

DIMENSIONS

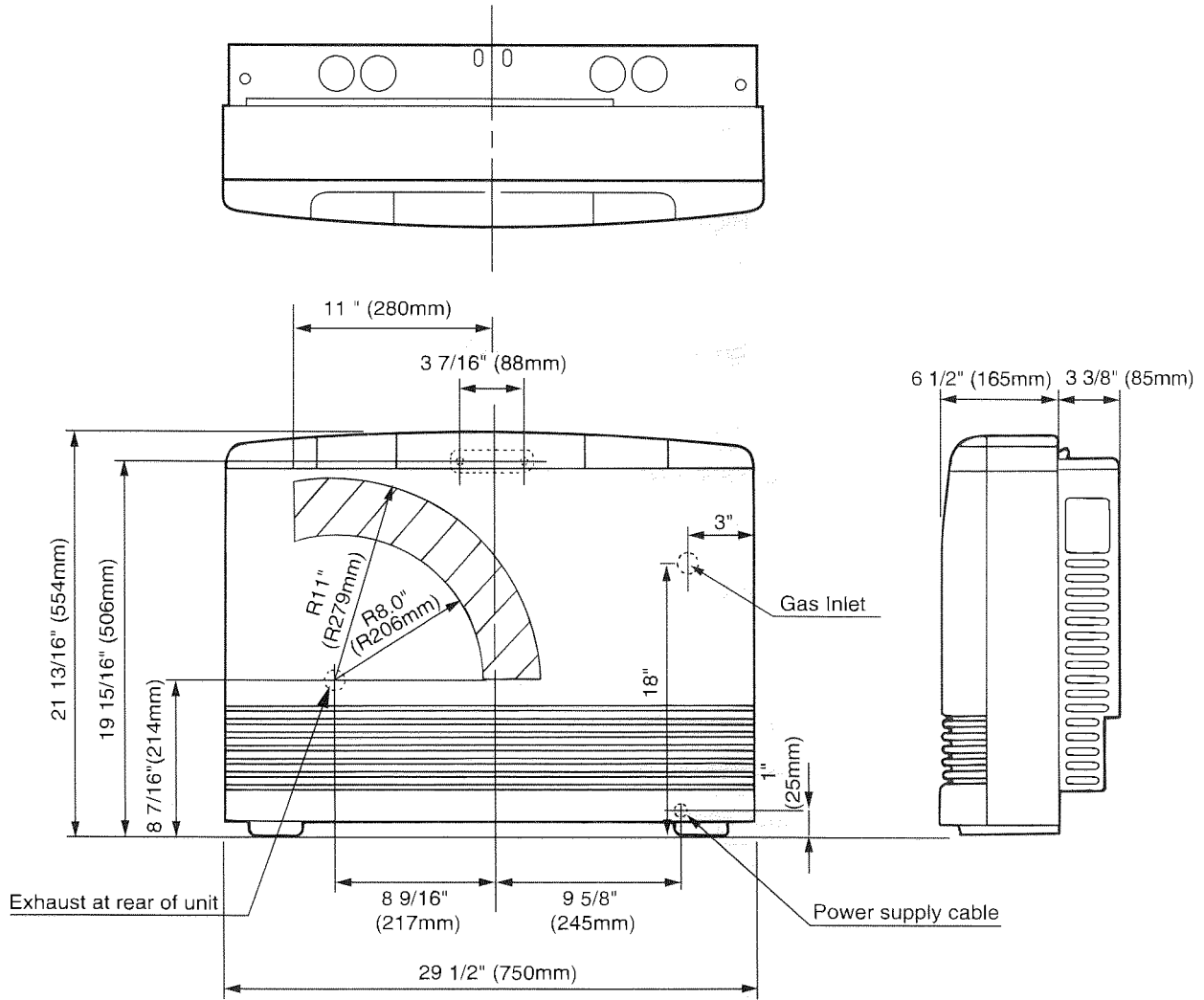

SPECIFICATIONS

MODEL #	BTU/h		MIN. CLEARANCES			FAN CFM OUTPUT
	INPUT	OUTPUT	SIDE	TOP	FRONT	
RHFE-431WTA	Low 8,200	Low 6,640	2" (50mm)	10" (250mm)	40" (1m)	LO:110.5
NATURAL	High 16,700	High 13,400				HI:141.3
RHFE-431WTA	Low 8,200	Low 6,640	2" (50mm)	10" (250mm)	40" (1m)	LO:110.5
PROPANE	High 16,700	High 13,400				HI:141.3

SPECIFICATIONS

Type of Appliance	Fan Type Direct Vent Wall Furnace	
Model	RHFE-431WTA ENERGY SAVER	
Dimensions	Width— 29 1/2" (750mm) Depth— 9 13/16" with back spacer (250mm with back spacer) Height— 21 13/16" (554mm)	
Weight	Approx. 51 lbs.	
Connections	Electrical—AC 120V 60Hz 43 watts Gas—1/2" female NPT	
Combustion System	Stainless steel bunsen burner	
Ignition System	Continuous spark	
Operation	Finger touch control buttons	
Temperature Control	Electronic thermostat HI-LOW/OFF Up/down switch	
Temperature Range	Normal Operation	Frost Function
	LOW=50°F 60°F~80°F HI=High Combustion	38°F~60°F
Warm Air Outlet	Bottom front louver	
Operating Buttons	On/off, Auto, Override, Economy, Frost, Timers, Select, Clock, Up/down	
Economy Mode	Energy saving feature	
Humidifier Tray	Capacity—3 pints (1300cc)	

Safety Devices	Flame failure – Flame rod Over heat – Bi-metal switch, thermal fuse, thermistor Power failure – PCB Power surge – 3 Amp. fuse Fan delay – Micro computer timer Pre-purge – Combustion fan, pre-purge timer, spark sensor Room over heat – Automatic cut off at 104°F after 10 minutes	
Noise Level Range	HI~LOW=38~32dB(A)	
TYPE	Combustion Method	Forced combustion
	Air Supply Exhaust	Closed Type
	Radiation Method	Forced convection
AIR SUPPLY/ EXHAUST PIPE	Wall Penetration Hole	3 1/8" (80mm)
	Max. Extended Length	(4m, 2 bends)=13ft., 2 bends

SPECIFICATIONS FOR VENT SIZES		
S	3"—4 1/2" (75—115mm)	Thin Walls Mobile Home
A	4 1/2"—9 1/2" (115—240mm)	Wood Walls
B	9 1/2"—15 3/4" (240—400mm)	Wood/Brick
C	15 3/4"—23 5/8" (400—600mm)	Brick/Block
D	23 5/8"—31 1/2" (600—800mm)	Special

** BTU - Efficiency increases with vent Extension. Clearances from combustibles see pages 3 and 18.

** Thermal efficiency rating determined under continuous operating conditions, and was determined independently of any installed system.

LOCATION / CLEARANCES

When positioning the heater the main points governing the location are:

1. Flueing
2. Warm air distribution

This heater is not designed to be build in.

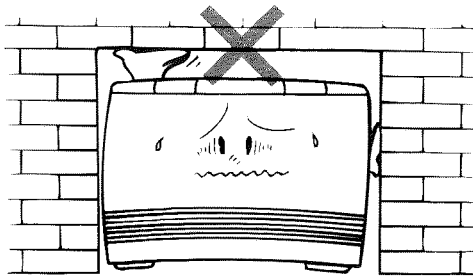

The flue is not designed to be positioned under floors, or below the level of the heater.

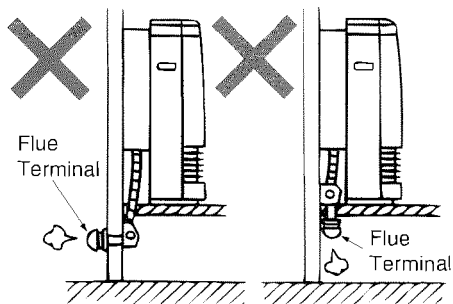

The flue terminal should be positioned away from flammable materials.

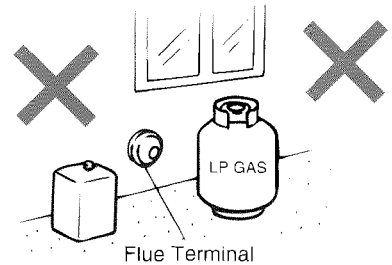

Do not flue into natural draught flues or fireplaces, this unit can only be used with one of the five types of Rinnai flue kits. Do not flue unit into other rooms. Flue terminal must be outside.

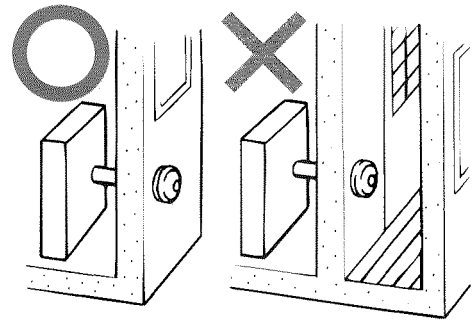

Flue may be positioned directly under opening windows, with a minimum clearance of 9" (230mm).

FLUE SIZES:

5 Flue lengths are available.

- S flue walls 3"~4 1/2" (75~115mm)
- A flue walls 4 1/2"~9 1/2" (115~240mm)
- B flue walls 9 1/2"~15 3/4" (240~400mm)
- C flue walls 15 3/4"~23 5/8" (400~600mm)
- D flue walls 23 5/8"~31 1/2" (600~800mm)